

HLT-111C

Hysteresis Loop Tracer



- Measures magnetic parameters accurately
- Demagnetisation, eddy currents and sample cross-sectional area have been accounted for
- Capable of detecting the number of magnetic phase present in a sample
- Computer Interface provided

Introduction

A precise knowledge of various magnetic parameters of ferromagnetic substances, viz. coercivity, retentivity, saturation magnetisation and hysteresis loss, and ability to determine them accurately are important aspects of magnetic studies.

The information about the aforementioned properties can be obtained from a magnetic hysteresis loop which can be traced by a number of methods in addition to the slow and laborious ballistic galvanometer method. Among the typical representatives of AC hysteresis loop tracers, some require the ring form of samples while others can be used with thin films, wires or even rock samples. Ring form samples are not always practically convenient to make while in others demagnetisation effects sometime become quite important.

The present set-up can accept the samples of thin wires of different diameters. The demagnetisation effects, different diameters of samples and eddy currents (due to the conducting property of the material) has been taken into account within the design or graphically.

Design Principle

When a cylindrical sample is placed coaxially in a periodically varying magnetic field the magnetisation in the sample also undergoes periodic variation. This variation is picked up by a coil, placed coaxially with the sample.

For the uniform field H_0 produced, the effective field H acting in the cylindrical sample will be

$$H = H_0 - NM$$

$$\text{or } H = H_0 - \frac{NJ}{\mu_0} \quad (1)$$

where M is magnetisation, N is normalised demagnetisation factor including 4π and J is the magnetic polarisation defined by

$$B = \mu_0 H + J$$

with $B = \mu H$ or $\mu_0(H + M)$ as magnetic induction. The signal corresponding to the applied field, H_a can be written as

$$e_1 = C_1 H_a \quad (2)$$

where C_1 is a constant

Further the flux linking with the pick-up coil of area A_c due to sample of area A_s will be

$$\phi = \mu_0 (A_c - A_s) H' + A_s B$$

where H' is the field in the excess area of the pick-up coil.

Under certain conditions this equation reduces to

$$\phi = \mu_0 A_c H + A_s J$$

The signal induced in the pick-up coil (e_2) will be proportional to $d\phi/dt$ which after integration yields

$$e_2 = C_3 \phi = C_3 \mu_0 A_c H + C_3 A_s J \quad (3)$$

Solving (1), (2) and (3) gives

$$C_1 C_3 A_c \left(\frac{A_s}{A_c} - N \right) J = C_1 e_2 - \mu_0 C_3 A_c e_1$$

$$C_1 C_3 A_c \left(\frac{A_s}{A_c} - N \right) J = C_3 A_s e_1 - \frac{N C_1 e_2}{\mu_0}$$

Based on these equations the electronic circuit has been designed to give values of J and H and hence the hysteresis loop. Further different magnetic phases present in the sample may also be identified by electronically manipulating the pick-up signal.

Description of the set-up

The block diagram of the set-up is given next and a brief description now follows:

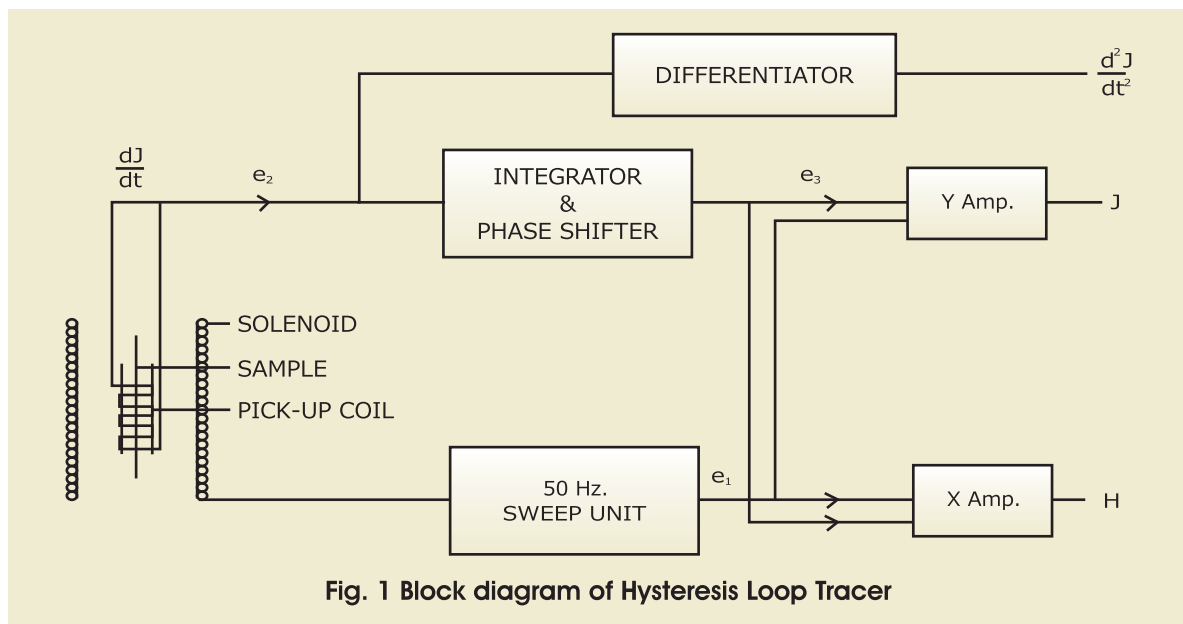

Fig. 1 Block diagram of Hysteresis Loop Tracer

Basic Circuit

The magnetic field has been obtained with an ac mains driven multilayered solenoid. This magnetic field has been calibrated with a Hall Probe for uniformity and correspondence with the magnetic field calculated through ac current passing in the solenoid. A small resistance in series with the solenoid serves the purpose of taking a signal e_1 corresponding to H .

The signal e_2 (corresponding to dJ/dt) is taken from the pick-up coil placed at the centre of the solenoid and contains the sample. It is integrated and corrected for phase. This signal is then subtracted from the reference signal e_1 and amplified to give the signal corresponding to J . The e_1 signal is also subtracted from $3e_3$ in correct ratio (to account for demagnetisation and area ratio) and amplified to give signal corresponding to H .

e_2 is also passed through the differentiator for getting signal corresponding to d^2J/dt^2 , which is used for phase identification.



Computer Interface, SES-CAMM

This interface enables the user to get a plot of the B-H Loop on the computer screen as soon as a magnetic field is set soon the hardware. Procedure for initial setting and conduction of experiment are available through the software provided with the unit. In the end, data would be stored in the excel format.

Applications

The following magnetic parameters can be measured by this set-up:

- Coercivity
- Retentivity
- Saturation magnetisation
- Various magnetic phase identification
- Hysteresis loss

The equipment is complete in all respect, including a set of samples (wires of Nickel, and different grades of iron etc.). A Cathode Ray Oscilloscope and a computer will however be required.

Computer is not included with the setup

